



JASIC[®]

EVO2.0



Jasic EVO EM-200CT

TFT-LCD Screen Fitting Instructions





EM-200CT TFT-LCD Screen Fitting Instructions



The following operation requires sufficient professional knowledge on electric aspects and comprehensive safety knowledge. Make sure the input cable of the machine is disconnected from the electricity supply and wait for 5 minutes before removing the machine covers.

The below fitting instructions will guide you through the process of removing the ClearVision control front panel and fitting the optional TFT-LCD control panel for the Jasic Evo EM-200CT.

To gain access to the front control panel fixing screws, open the access door to the wire feed area and using a crosshead screwdriver remove the two retaining screws (A) as shown below. To gain access to the front control board wiring connections, remove the 8 screws (B) of the right hand side panel.

Control panel retaining screws (A)

8 fixing side panel screws (B)

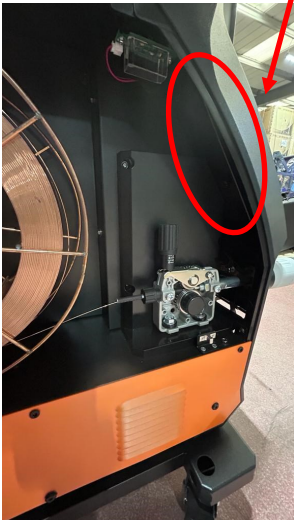

Access holes and rubber grommet (C)

Front panel earth wire (D)

Ribbon cable plug and socket (E)

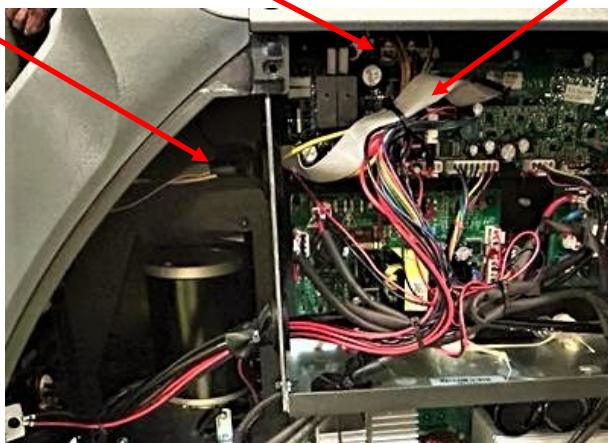

Once the retaining screws (A) and the side panel have been removed, you will see the cable route as shown left of the front screen control ribbon cable and the earth cable which go through two panel holes.

Now proceed to disconnect the ClearVision control screen ribbon cable plug (E) by unclipping the plug from the socket. Use a crosshead screwdriver to remove the fixing screw which connects the earth wire eyelet to the chassis earthing point (D).

Access hole and rubber grommet (C)

Front panel earth wire (D)

Ribbon cable plug and socket (E)

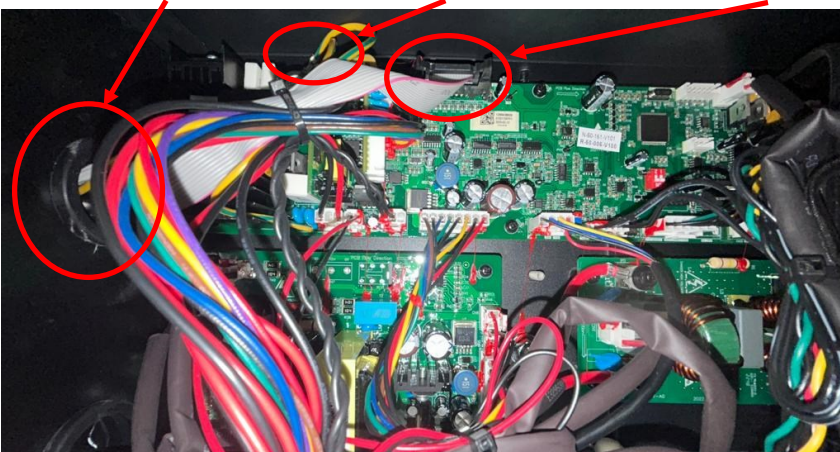

Once these are disconnected and any cable ties have been removed, you can now proceed to slowly pull the front control panel away although be careful when pulling the ribbon cable/plug and earth wire through the 2 access holes (C) that you don't damage either of these cables or surrounding PCB's. Please take note that black rubber grommets are fitted in the access holes (C) to reduce dust ingress, these will most likely come out when you remove the cables, please ensure that you refit the grommets when passing the new cable assembly back through (C).



ET-200CT TFT-LCD Screen Fitting Instructions



The following operation requires sufficient professional knowledge on electric aspects and comprehensive safety knowledge. Make sure the input cable of the machine is disconnected from the electricity supply and wait for 5 minutes before removing the machine covers.



Once removed, now proceed to fit the supplied 4 wire control cable assembly (F).

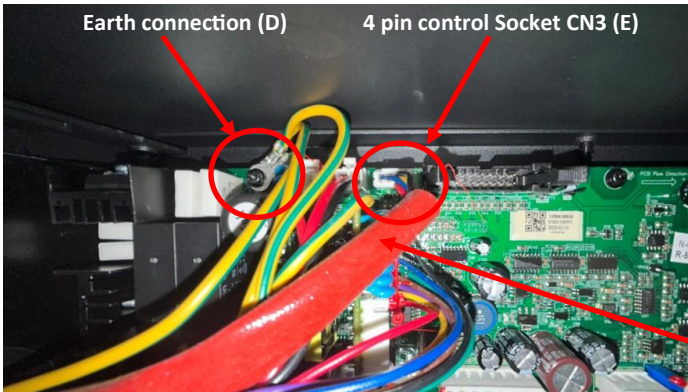

Feed the cable assembly from the front through the two access holes (rubber grommets) and connect the 4 pin plug to CN3 as shown in the image left. Ensure that the grommets (K) are firmly in place.

If applicable, pass the control panel earth wire through both access holes and grommets and using a crosshead screwdriver reconnect the earth wire eyelet to the chassis earthing point (D) located just above the PCB.

4 wire control cable assembly (F)

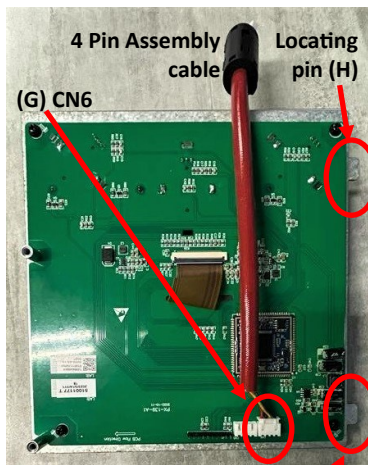

Connect the other end of the 4 pin cable assembly to the TFT-LCD screen control socket CN6 (G) as shown left.

With the front fascia of the control panel facing you, you will note to the left two locating pins that are part of the front control panel, these pins are designed to locate into the two slots within the front black panel again as shown left in the two images.

Now, carefully align the front control panel pins (G) into place ensuring the cable assembly behind the control panel is not being pinched or crushed. Refit the 2 control panel fixing screws to resecure the new front control panel in place as shown on the previous page (A).

If not already done, route and secure the earth wire to the chassis earthing point as shown above (D) and fit the 4 pin cable assembly plug to the control PCB socket CN3 (E) as shown above.



You can now proceed to re-install the machines side panel as shown on the previous page (B).

Carefully store the old ClearVision control panel away for safe keeping.

Go to Jasic.co.uk and navigate to the EM-200CT product page to download the operating manual which include the TFT-LCD screen operating instructions.

Please Note:

It's recommended during the above installation procedure an anti-static strap should be worn.





Wilkinson Star Limited

Shield Drive
Wardley Industrial Estate
Worsley
Manchester
UK
M28 2WD

+44(0)161 793 8127

 **JASIC®** | Passionate About Your Welding

www.jasic.co.uk

June 2023 Issue 1