



# JASIC®

## EVO2.0



## Operator Manual

### HRC-01, HRC-02 & HRC-04

Wired and Wireless Remote Control



# Your new product



Jasic.co.uk

Thank you for selecting this Jasic EVO 20 product.

This product manual has been designed to ensure that you get the most from your new product. Please ensure that you are fully conversant with the information provided paying particular attention to the safety precautions. The information will help protect yourself and others against the potential hazards that you may come across.

Please ensure that you carry out daily and periodic maintenance checks to ensure years of reliable and trouble free operation.

Please call your Jasic distributor in the unlikely event of a problem occurring. Please record below the details from your product as these will be required for warranty purposes and to ensure you get the correct information should you require assistance or spare parts.

Date purchased \_\_\_\_\_

From where \_\_\_\_\_

Serial number \_\_\_\_\_

(The serial number is normally located on the top or underside of the machine and will begin with AA)

For further information on your Jasic product warranty registration please visit:

[www.jasic-warranty.co.uk](http://www.jasic-warranty.co.uk)

## Disclaimer

Whilst every effort has been made to ensure that the information contained within this manual is complete and accurate, no liability can be accepted for any errors or omissions.

## Please Note:

Products are subject to continual development and may be subject to change without notice. Regularly check our product pages at [www.jasic.co.uk](http://www.jasic.co.uk) for revision updated operating manuals.

No part of this manual may be copied or reproduced by any means without the written permission of Wilkinson Star Limited.

# CONTENTS

<b>Index</b>	<b>Page</b>
Your New Product	2
Index	3
Safety Instruction	4
Package and Contents	9
Safety Precautions	10
Description of Symbols	10
Product Overview	10
Technical Specifications	10
Installation	11
Remote Description	13
Battery Replacement	13
Functions and operation of wireless remote control	14
Functions and operation of wired remote control	15
Troubleshooting	15
Transportation	15
Waste disposal	15
RoHS Compliance Declaration	15
Statement of Warranty	16
Notes	18
Jasic Contact Details	20

# SAFETY INSTRUCTIONS



These general safety norms cover both arc welding machines and plasma cutting machines unless otherwise noted. The user is responsible for installing and operating the equipment in accordance with the enclosed instructions.

It is important that users of this equipment protect themselves and others from harm, or even death. The equipment must only be used for the purpose it was designed for. Using it in any other way could result in damage or injury and in breach of the safety rules.

Only suitably trained and competent persons should operate the equipment.

Pacemaker wearers should consult their doctor prior to using this equipment.

PPE and workplace safety equipment must be compatible for the application of the work involved.

**Always carry out a risk assessment before carrying out any welding or cutting activity.**

## General electrical safety



**Danger**

**Electric shock risk**

The equipment should be installed by a qualified person and in accordance with current standards in operation.

It is the users responsibility to ensure that the equipment is connected to a suitable power supply. Consult your utility supplier if required.

Do not use the equipment with the covers removed. Do not touch live electrical parts or parts which are electrically charged. Turn off all equipment when not in use.

In the case of abnormal behaviour of the equipment, the equipment should be checked by a suitably qualified service engineer.

If earth bonding of the work piece is required, bond it directly with a separate cable with a current carrying capacity capable of carrying the maximum capacity of the machine current.

Cables (both primary supply and welding) should be regularly checked for damage and overheating.

Never use worn, damaged, under sized or poorly jointed cables.

Insulate yourself from work and earth using dry insulating mats or covers big enough to prevent any physical contact.

Never touch the electrode if you are in contact with the work piece return.

Do not wrap cables over your body.

Ensure that you take additional safety precautions when you are welding in electrically hazardous conditions such as damp environments, wearing wet clothing and metal structures.

Try to avoid welding in cramped or restricted positions.

Ensure that the equipment is well maintained. Repair or replace damaged or defective parts immediately.

Carry out any regular maintenance in accordance with the manufacturers instructions.

The EMC classification of this product is class A in accordance with electromagnetic compatibility standards CISPR 11 and IEC 60974-10 and therefore the product is designed to be used in industrial environments only.

**WARNING:** This class A equipment is not intended for use in residential locations where the electrical power is provided by a public low-voltage supply system. In those locations it may be difficult to ensure the electromagnetic compatibility due to conducted and radiated disturbances.

## General operating safety



Never carry the equipment or suspend it by the carrying strap or handles during welding.

Never pull or lift the machine by the welding torch or other cables.

Always use the correct lift points or handles. Always use the transport under gear as recommended by the manufacturer.

Never lift a machine with the gas cylinder mounted on it.

If the operating environment is classified as dangerous, only use S-marked welding equipment with a safe idle voltage level. Such environments may be for example: humid, hot or restricted accessibility spaces.

# SAFETY INSTRUCTION

## **⚠ CAUTION** Use of Personal Protective Equipment (PPE)

**PPE REQUIRED AT ALL TIMES** Welding arc rays from all welding and cutting processes can produce intense, visible and invisible (ultraviolet and infrared) rays that can burn eyes and skin.

- Wear an approved welding helmet fitted with an appropriate shade of filter lens to protect your face and eyes when welding, cutting or watching.
- Wear approved safety glasses with side shields under your helmet.
- Never use any equipment that is damaged, broken or faulty.
- Always ensure there are adequate protective screens or barriers to protect others from flash, glare and sparks from the welding and cutting area.
- Ensure that there are adequate warnings that welding or cutting is taking place.
- Wear suitable protective flame resistant clothing, gloves and footwear.
- Ensure adequate extraction and ventilation is in place prior to welding and cutting to protect users and all workers nearby.
- Check and be sure the area is safe and clear of flammable material before carrying out any welding or cutting.



Some welding and cutting operations may produce noise. Wear safety ear protection to protect your hearing if the ambient noise level exceeds the local allowable limit (e.g: 85 dB).

### Welding and Cutting Lens Shade Selector Guide

WELDING CURRENT	MMA ELECTRODES	MIG LIGHT ALLOY	MIG HEAVY METALS	MAG	TIG ALL METALS	PLASMA CUTTING	PLASMA WELDING	GOUGING ARC/AIR
10	8	10	10	10	9	11	10	10
15								
20								
30	10							
40								
60	10	11	11	11	12			
80								
100	11	11	11	11	12	13	11	
125								
150		12	12	13	13	13	14	
175								
200								
225	12	12	12	13	13	14	12	
250								
275		13	13	14	14	14	13	
300								
350								
400	13	14	13	14	14	13	14	
450								
500								14

# SAFETY INSTRUCTION

## Safety against fumes and welding gases



**Warning**  
Fumes and  
Gases

The HSE have identified welders as being an 'at risk' group for occupational diseases arising from exposure to dusts, gases, vapours and welding fumes. The main identified health effects are pneumonia, asthma, chronic obstructive pulmonary disease (COPD), lung and kidney cancer, metal fume fever (MFF) and lung function changes.

During welding and hot cutting 'hot work' operations, fumes are produced which are collectively known as welding fume. Depending upon the type of welding process being performed, the resultant fume generated is a complex and highly variable mixture of gases and particulates. Regardless of the length of welding being carried out, all welding fume, including mild steel welding requires suitable engineering controls to be in place which is usually Local Exhaust Ventilation (LEV) extraction to reduce the exposure to welding fume indoors and where LEV does not adequately control exposure it should also be enhanced by using suitable respiratory protective equipment (RPE) to assist with protecting against residual fume.

When welding outdoors appropriate RPE should be used.

Prior to undertaking any welding tasks an appropriate risk assessment should be carried out to ensure expected control measures are in place.



An example of personal fume protection

Locate the equipment in a well-ventilated position and keep your head out of the welding fume.

Do not breathe in the welding fume.

Ensure the welding zone is well-ventilated and provision should be made for suitable local fume extraction system to be in place.

If ventilation is poor, wear an approved airfed welding helmet or respirator.

Read and understand the Material Safety Data Sheets (MSDS's) and the manufacturer's instructions for metals, consumable, coatings, cleaners and de-greasers.

Do not weld in locations near any de-greasing, cleaning or spraying operations.

Be aware that heat and rays of the arc can react with vapours to form highly toxic and irritating gases.

**For further information please refer to the HSE website [www.hse.gov.uk](http://www.hse.gov.uk) for related documentation.**

## Precautions against fire and explosion



**Caution**  
Risk of fire

Avoid causing fires due to sparks and hot waste or molten metal.

Ensure that appropriate fire safety devices are available near the welding and cutting area.

Remove all flammable and combustible materials from the welding, cutting and surrounding areas.

Do not weld or cut fuel and lubricant containers, even if empty. These must be carefully

cleaned before they can be welded or cut.

Always allow the welded or cut material to cool before touching it or

placing it in contact with combustible or flammable material.

Do not work in atmospheres with high concentrations of combustible fumes, flammable gases and dust.

Always check the work area half an hour after cutting to make sure that no fires have begun.

Take care to avoid accidental contact of the torch electrode to metal objects, as this could cause arcs, explosion, overheating or fire.

## **Know and understand your fire extinguishers**

	Water	Foam spray	ABC powder	Carbon dioxide	Wet chemical
<i>Symbols found on fire extinguishers &amp; what they mean</i>					
Flammable Wood, paper & textiles	✓	✓	✓	✗	✓
Flammable liquids	✗	✓	✓	✓	✗
Flammable gases	✗	✗	✓	✗	✗
Electrical contact	✗	✗	✓	✓	✗
Cooling oil & fats	✗	✗	✗	✗	✓

# SAFETY INSTRUCTION

## The working environment



Ensure the machine is mounted in a safe and stable position allowing for cooling air circulation.  
Do not operate equipment in an environment outside the laid down operating parameters.  
The welding power source is not suitable for use in rain or snow.

Always store the machine in a clean, dry space.

Ensure the equipment is kept clean from dust build up.

Always use the machine in an upright position.

## Protection from moving parts



When the machine is in operation keep away from moving parts such as motors and fans.

Moving parts, such as the fan, may cut fingers and hands and snag garments.

Protections and coverings may be removed for maintenance and managed only by qualified personnel after first disconnecting the power supply cable.

Replace the coverings and protections and close all doors when the intervention is finished and before starting the equipment.

Take care to avoid getting fingers trapped when loading and feeding wire during set up and operation.

When feeding wire be careful to avoid pointing it at other people or towards your body.

Always ensure machine covers and protective devices are in operation.

## Risks due to magnetic fields



The magnetic fields created by high currents may affect the operation of pacemakers or electronically controlled medical equipment.

Wearers of vital electronic equipment should consult their physician before beginning any arc welding, cutting, gouging or spot welding operations.

**Warning**  
Strong magnetic field

Do not go near welding equipment with any sensitive electronic equipment as the magnetic fields may cause damage.

Keep the torch cable and work return cable as close to each other as possible throughout their length.

This can help minimise your exposure to harmful magnetic fields.

Do not wrap the cables around the body.

## Handling of compressed gas cylinders and regulators



Mishandling gas cylinders can lead to rupture and the release of high pressure gas.

Always check the gas cylinder is the correct type for the welding to be carried out.

Always store and use cylinders in an upright and secure position.

**Danger**  
Compressed gas

All cylinders and pressure regulators used in welding operations should be handled with care.

Never allow the electrode, electrode holder or any other electrically “hot” parts to touch a cylinder.

Keep your head and face away from the cylinder valve outlet when opening the cylinder valve.

Always secure the cylinder safely and never move with regulator and hoses connected.

Use a suitable trolley for moving cylinders.

Regularly check all connections and joints for leaks.

Full and empty cylinders should be stored separately.

## **Never deface or alter any cylinder**

# SAFETY INSTRUCTIONS

## Fire awareness



The cutting and welding process can cause serious risks of fire or explosion. Cutting or welding sealed containers, tanks, drums or pipes can cause explosions. Sparks from the welding or cutting process can cause fires and burns. Check and risk assess the area is safe before doing any cutting or welding. Ventilate all flammable or explosive vapour from the workplace.

Remove any and all flammable materials away from the working area. If necessary, cover flammable materials or containers with approved covers (following manufacturers instructions) if unable to remove from the immediate area.

Do not cut or weld where the atmosphere may contain flammable dust, gas or liquid vapour. Always have the appropriate fire extinguisher nearby and know how to use it.

## Hot parts



Always be aware that material being cut or welded will get very hot and hold that heat for a considerably long time which will cause severe burns if the appropriate PPE is not worn. Do not touch hot material or parts with bare hands.

Always allow for a cooling down period before working on material recently cut or welded. Use the appropriate insulated welding gloves and clothing to handle hot parts to prevent burns.

## Noise awareness



The cutting and welding process can generate noise that can cause permanent damage to your hearing. Noise from cutting and welding equipment can damage hearing.

Always protect your ears from noise and wear approved and appropriate ear protection if noise levels are high.

Consult with your local specialist if you are unsure how to test for noise levels.

## RF Declaration



Equipment that complies with directive 2014/30/EU concerning electromagnetic compatibility (EMC) and the technical requirements of EN60974-10 is designed for use in industrial buildings and not for domestic use where electricity is provided via the low voltage public distribution system.

Difficulties may arise in assuring class A electromagnetic compatibility for systems installed in domestic locations due to conducted and radiated emissions.

In the case of electromagnetic problems, it is the responsibility of the user to resolve the situation.

It may be necessary to shield the equipment and fit suitable filters on the mains supply.

## LF Declaration



Consult the data plate on the equipment for the power supply requirements.

Due to the elevated absorbance of the primary current from the power supply network, high power systems affect the quality of power provided by the network. Consequently, connection restrictions or maximum impedance requirements permitted by the network at the public network connection point must be applied to these systems.

In this case, the installer or the user is responsible for ensuring the equipment can be connected, consulting the electricity provider if necessary.



# SAFETY INSTRUCTION

## Materials and their disposal



Welding equipment is manufactured with BSI published standards meeting CE requirements for materials which do not contain any toxic or poisonous materials dangerous to the operator. Do not dispose of the equipment with normal waste.



The European Directive 2012/19/EU on Waste Electrical and Electronic Equipment states that electrical equipment that has reached its end of life must be collected separately and returned to an environmentally compatible recycling facility for disposal.

**For more detailed information please refer to the HSE website [www.hse.gov.uk](http://www.hse.gov.uk)**

## PACKAGE CONTENTS AND UNPACKING

Supplied within your new Jasic EVO product package will be the following items with each model.

Use care when unpacking the contents and ensure all items are present and not damaged.

If damage is noted or items are missing, please contact the supplier in the first instance and before installing or using the product. Record the product model, serial numbers (if applicable) and purchase date in the information section found on the inside front page of this operating manual.

- Jasic EVO HRC-01 (9 pin Wired Hand Remote Control)
- Jasic EVO HRC-02 (Wireless Hand Remote Control)  
c/w Remote Control Receiver Module
- Jasic EVO HRC-04 (3 pin Wired Hand Remote Control)

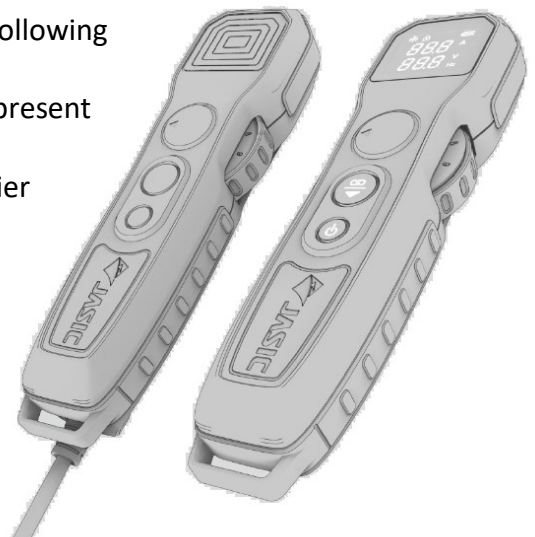

Remote Model	Suitable machine	Remote Control Function	Range
<b>HRC-01</b> (9 pin plug fitted, Pt No JSG-PLUG-9PIN )	EM-160C/EM-200C EM-200CT/EM250CT ET-200/ET-200P ET-200PACDC	Adjust welding current in MMA mode	15m (5m cable fitted)
<b>HRC-02</b> (Wireless)	EM-160C/EM-200C EM-200CT/EM250CT	<b>In MIG non-synergic mode:</b> Adjust wire feeding speed and welding voltage. <b>In MIG synergic mode:</b> Adjust welding current, and welding voltage. <b>In Lift TIG mode:</b> Adjust welding current.	30M
	ET-200/ET-200P ET-200PACDC	<b>DC TIG:</b> Adjust welding current. <b>DC pulse TIG:</b> Adjust welding current and pulse frequency. <b>AC (pulse) TIG:</b> Adjust welding current and AC balance.	
<b>HRC-04</b> (3 pin plug fitted, Pt No 10083740)	EA-160/EA-200	Adjust welding current on MMA	15m (5m cable fitted)

### Please Note:

- Package contents may vary depending on country location and package part number purchased
- For further information regarding the operation/setup of remote control, please consult your EVO machine operating manual.

# SAFETY PRECAUTIONS



The following operations require sufficient professional knowledge on electrical aspects and comprehensive safety knowledge. Make sure the input cable of the machine is disconnected from the electricity supply and wait for 5 minutes before removing the machine covers.

## Description of symbols



Warning! Read the Manual



WEEE tag



Power button



Wireless connection button



Bluetooth connection status



Battery power status



Standby state

## Product Overview

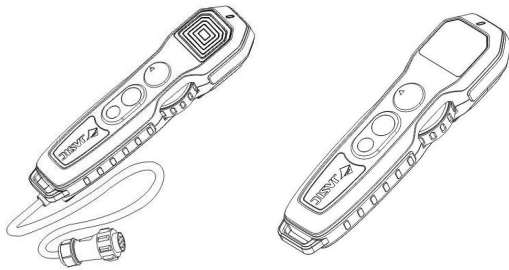

These lightweight wired and wireless handheld remote controls are easy to use and operate.

They are compatible for current control for the MMA and TIG modes and some parameter aspects of MIG modes of the EVO series welding machines.

The wired remotes come as either 3pin or 9pin plugs and the standard cable length is 5m, with the maximum optional length of 10m.

The silicone cable of the remote controller features wear, corrosion and high temperature resistance.

Wireless handheld remote controller is a remote controller supporting Bluetooth wireless technology. These remotes are compatible with the EVO series welding machines and features easy to use design, practical and convenient operation with great performance and long remote control distance. They can be generally used in MMA, TIG and MIG welding modes, with the maximum transmission distance of 30m.

## Technical Parameters

Item	Unit	Parameter		
Model	-	HRC-01	HRC-02	HRC-04
Connection Type	-	Wired (9 pin)	Wireless	Wired (3 pin)
Operating Voltage	V	5V DC	Qty 2 1.5V (AA batteries)	5V DC
Maximum Working Distance	m	10m	30m open distance. (To be used a minimum of 1m above ground in open environment).	10m
Battery Life	Hrs	N/A	250	N/A
Protection Class	-	IP23	IP23	IP23
Dimensions L x W x H	mm	250 x 168 x 44	203 x 52 x 32	250 x 168 x 44
Net Weight	g	29.2	29.2	29.2
Overall Weight	g	105	105	105
Protection	-	ROHS2.0	ROHS2.0	ROHS2.0

# INSTALLATION OF WIRELESS REMOTE CONTROL RECIEVER MODULE



The below operation requires sufficient professional comprehensive knowledge of electrical circuits and electrical safety. Make sure the input cable of the machine is disconnected from the electricity supply and wait for 5 minutes before removing the machine covers.

## Installation of wireless receiver module

The HRC-01, HRC-02 and HRC-04 remote control unit can be used with the following EVO machine models:

EA-160 & EA-200	(HRC-04)
EM-160C & EM-200C	(HRC-01 & HRC-02)
EM-200CT & EM-250CT	(HRC-01 & HRC-02)
ET-200 & ET-200P	(HRC-01 & HRC-02)
ET-200P ACDC	(HRC-01 & HRC-02)

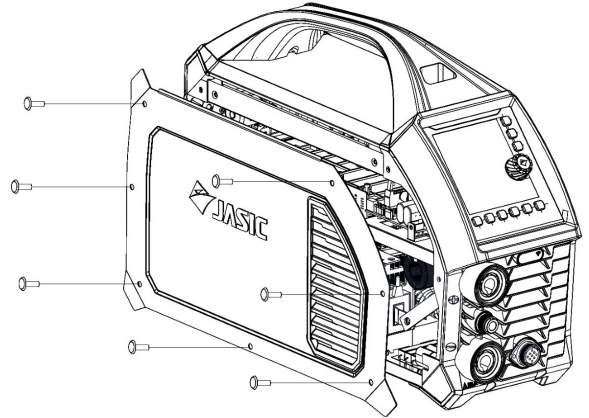

## Wireless hand-held remote-control connection

An option with the EVO range of machines is for the operator to be able to wirelessly control the welding current.

To enable this then you will require to fit the optional remote interface module.

- 1) Ensure machine is unplugged from the machines supply
- 2) Leave the machine at least 5 minutes before removing any covers
- 3) Remove the screws on the left cover of the machine.
- 4) Carefully place the panel to one side
- 5) You now have access to the inside front area of the machine

## Installation of the wireless receiver module

- 1) Remove the plastic cap 'A' shown in the image right and fit the wireless receiver module as shown.
- 3) If you haven't already, remove the screws of the left side cover (for ET-200/P), left side panel and the lid for the ET-200PACDC and the right hand side panels for the EM-MIG models as described above.
- 4) Remove the buckle from inside the front panel of the machine and pull out the plug (A).
- 5) The wire receiver (as shown below) C will fit into the machine by first feeding the cable connector and cable through the front panel hole where you removed the plastic cap (A)
- 5) Now insert the receiver module 'B' to the front panel (notches up), and then clip the module in place

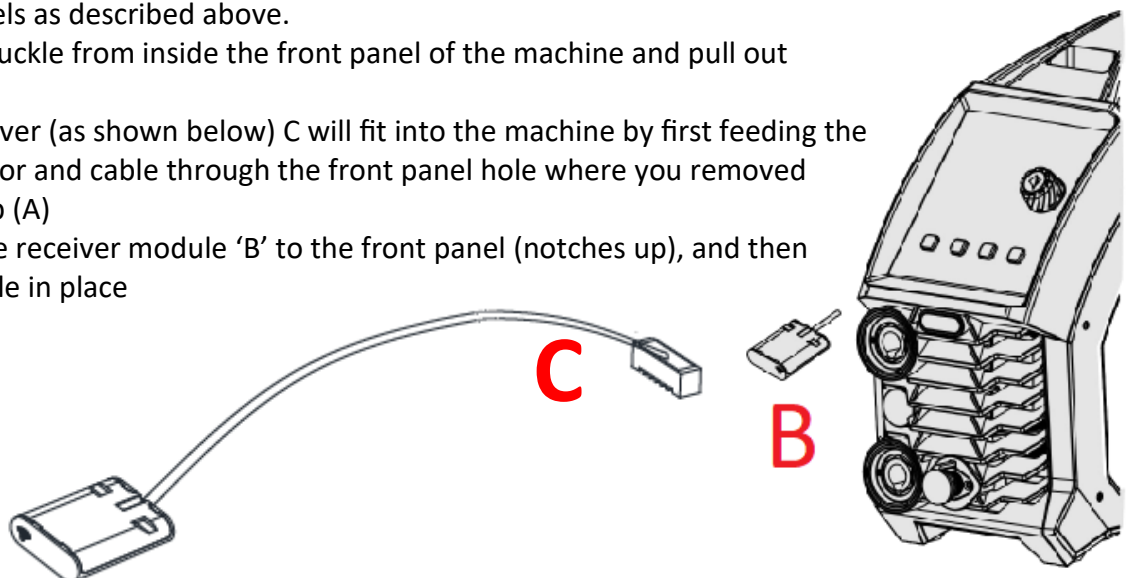
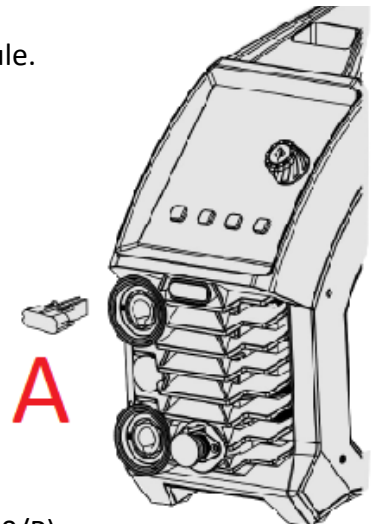

## PLEASE NOTE:

Please check that your machine supports wireless hand held or foot remote controls before installation.

# INSTALLATION OF WIRELESS REMOTE CONTROL RECIEVER MODULE

## An Installation of wireless receiver module



The below operation requires sufficient professional comprehensive knowledge of electrical circuits and electrical safety. Make sure the input cable of the machine is disconnected from the electricity supply and wait for 5 minutes before removing the machine covers.

6. Following fitting the receiver module in place, you now need to connect the cable connector to the main PCB as shown below.
7. Fit the cable plug to the socket on the relevant PC Board as shown below of each EVO machine.

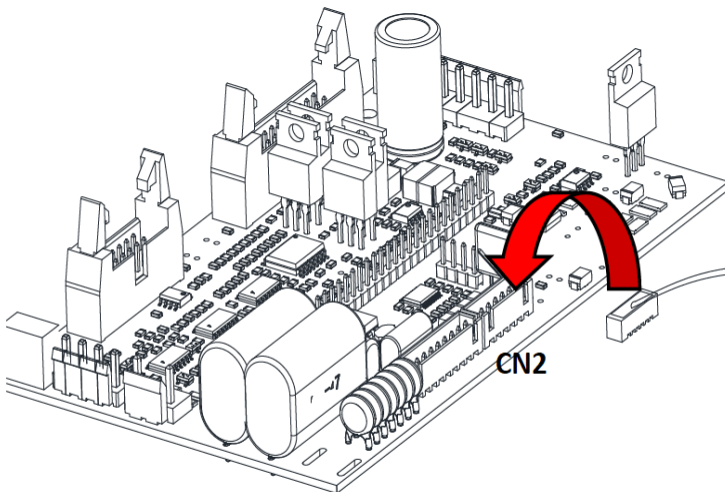

This image shows the main control board layout for inserting the wireless module plug in to the PCB socket CN2 for the EVO ET-200PACDC TIG machine.

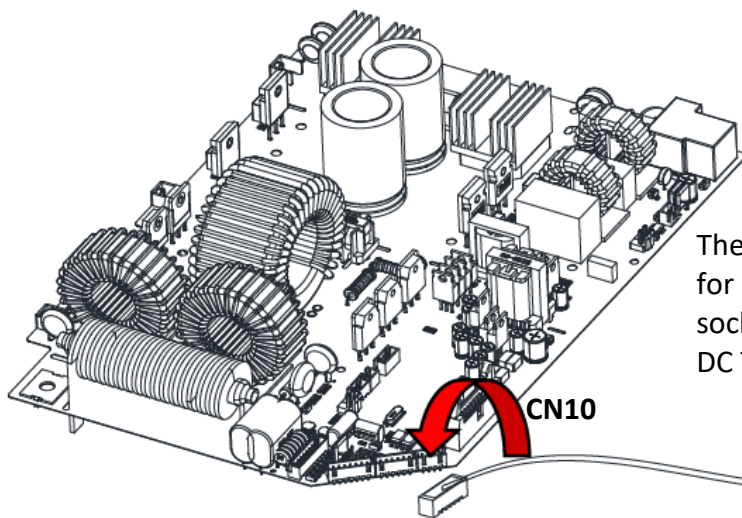

The image left shows the main control board layout for inserting the wireless module plug in to the PCB socket CN10 for the EVO TIG ET-200 and EM-200P DC TIG machines.

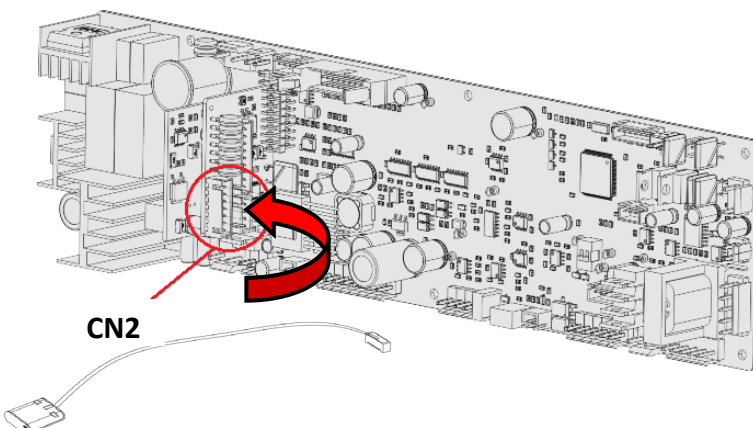

This image left shows the main control board layout for inserting the wireless module plug in to the PCB2 socket CN2 for the EVO EM-160C/200C and EM-200CT/250CT MIG machine range.

# DESCRIPTION OF THE WIRED & WIRELESS HAND REMOTE CONTROLS

Three hand held wired/wireless remote controls are available in this design, the HRC-01 (wired 9 pin), HRC-02 (wireless) and the HRC-04 Wired 3 pin) remote and can be used with the following EVO machine models:

- EA-160 & EA-200 (HRC-04)
- EM-160C & EM-200C (HRC-01 & HRC-02)
- EM-200CT & EM-250CT (HRC-01 & HRC-02)
- ET-200 & ET-200P (HRC-01 & HRC-02)
- ET-200P ACDC (HRC-01 & HRC-02)

## HRC-01 and HRC-04 Hand held wired remote controls:

- A. Current adjustment control dial
- B. Remote control connection cable
  - HRC-01 wired with 9 pin control plug
  - HRC-04 wired with 3 pin control plug

## HRC-02 Hand held wireless remote control:

- C. Wireless remote control display area
- D. Wireless connection button
- E. Current adjustment control dial
- F. Power on and off button

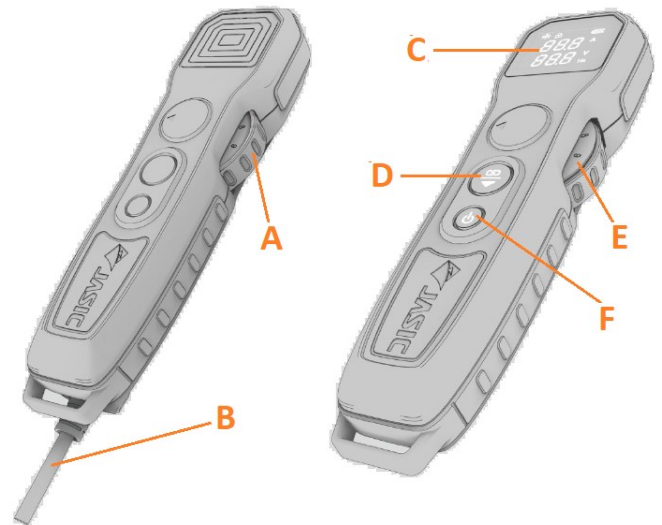

# FITTING OF BATTERIES FOR WIRELESS HAND REMOTE CONTROL

The remote control is fitted with qty 2 1.5 AA type battery which are designed to last approximately 250hrs based of operation actions of the remote controller.

When required, please follow the below procedure when replacing the battery.

1. Carefully using a small screwdriver remove the cover retaining screw as shown in the image below item (A).
2. Remove the battery protective cover (B).
3. Remove and then install the correct sized and rated replacement batteries as shown in image right (C).
4. Now re-install the back cover of the remote controller.
5. There is also a belt clip attachment for the remote which can be removed as shown above (D)

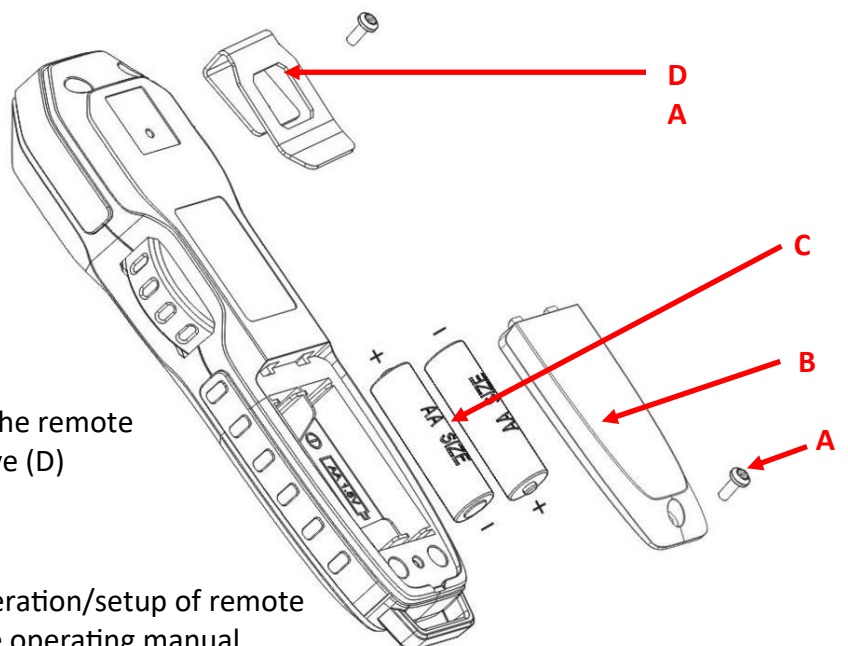

## Please Note:

For further information regarding the operation/setup of remote control, please consult your EVO machine operating manual.

# OPERATION OF THE WIRELESS HAND REMOTE CONTROL

## Wireless connection

Depending on the model and user interface of your EVO model the below instructions may differ, please refer to your EVO product operating manual for further instructions.

## Powering up your wireless controller

To power up your hand remote controller, press the power button of the controller and the power indicator will then turn on.

To turn off your hand remote, press and hold the power button and the device will be powered off.

## Pairing up your wireless controller

Model dependent and following powering up the machine up but before welding, activate the wireless connection option and blue indicator on the receiver module will flash.

At the same time, press the wireless "Connect" button of the wireless remote controller and after the EVO machine control panel displays "OK" and the blue indicator will remain 'ON' this indicates that the wireless connection is successful and the remote and machine have paired up.

## Current/parameter adjustment operation

Following successful pairing of your wireless connection, press the power button of the remote controller, and by rotating the knob to adjust the welder current and display the value on the LCD screen on the wireless handheld remote controller in real time; after completing the parameter adjustment you can press the power button of the remote controller to enter lock mode which deactivates the controls so to avoid mis-operation.

For normal use of the remote controller, ensure you have enabled the remote function via the control panel of EVO machine.

If the remote controller is not operated for a period of time, it will enter into standby mode and then powers down after 10s and 10 min, respectively.

When the battery of the wireless hand controller is low, the indicator will flash.

Remote Model	Suitable machine	Remote Control Function	Range
HRC-02	EM-160C / EM-200C EM-200CT / EM250CT	On MIG non-synergic mode: Adjusts wire feed speed and welding voltage. On MIG synergic mode: Adjusts welding current, and welding voltage. On Lift TIG mode: Adjusts welding current.	30m
	ET-200 / ET-200P ET-200P ACDC	DC TIG: Adjusts welding current. DC pulse TIG: Adjusts welding current and pulse frequency. AC (pulse) TIG: Adjusts welding current and AC balance.	

## PLEASE NOTE:

- After successfully connecting the wireless remote controller, do not press and hold the wireless "Connect" button again during normal use; otherwise, it will disconnect itself from the welding machine. To reconnect the remote device, you would need to repeat the above steps of wireless connection!
- Please operate the wireless remote controller at a distance of more than 1m from the ground, otherwise, the transmission distance will be affected!
- For further information regarding the operation/setup of remote control, please consult your EVO machine operating manual.

# OPERATION OF THE WIRED HAND REMOTE CONTROL

## Wired connection

Depending on the model and user interface of your EVO model the below instructions may differ, please refer to your EVO product operating manual for further instructions.

### Connecting your wired controller

Model dependent and prior to powering up your EVO machine, when fitting either the 3 or 9 pin remote plug, ensure you align the keyway when inserting the plug, then rotate the threaded collar fully clockwise until finger tight and shown right.

HRC-01 (9 pin connector)

HRC-04 (3 pin connector)

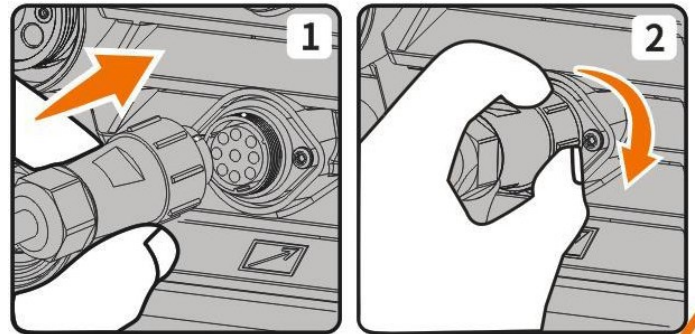

### Current/parameter adjustment operation

After successfully inserting the connector plug of the wired handheld remote control to the machine, power up your EVO machine and then enable the remote control function of the machine.

The wired handheld remote control can then be used for adjusting welding current in MMA and Lift TIG welding modes.

Remote Model	Suitable machine	Remote Control Function	Range
<b>HRC-01</b> (9 pin plug fitted, Pt No JSG-PLUG-9PIN )	EM-160C / EM-200C EM-200CT / EM250CT ET-200 / ET-200P ET-200P ACDC	Adjust welding current on MMA mode only	15m 5m fitted as standard
<b>HRC-04</b> (3 pin plug fitted, Pt No 10083740)	EA-160 / EA-200	Adjust welding current in MMA mode and Lift-TIG mode	

### Please Note:

For further information regarding the operation/setup of remote control, please consult your EVO machine operating manual.

# TROUBLESHOOTING



The following operation requires sufficient professional knowledge on electric aspects and comprehensive safety knowledge. Make sure the input cable of the machine is disconnected from the electricity supply and wait for 5 minutes before removing any machine covers.

Symptoms	Reason	Troubleshooting
The wireless remote controller cannot adjust the welding current	Wireless remote control not connected	Reconnect wireless mode from the welding machine to the remote control device. Reboot the welding machine.
	The wireless remote controller batteries are out of power	Replace the remote controllers batteries.
	Using the remote from too great a distance or there are too many obstacles in the way	Reposition the EVO welding machine closer to the welding job and try again. Remove any obstacles that maybe in the way
Other malfunctions		Check the connection of the receiver module to the main control PCB. Possible fault with controller of receiver module, try replacing either one of the items.

The above chart lists general problems that maybe experienced with a wireless remote controller

## Packaging, transportation, storage and waste disposal

### Transportation requirements

When handling the remote control, the device should always be handled with care, and should not be dropped or severely impacted. Avoid moisture and rain during transportation.

### Storage

Storage temperature: -25°C - +50°C

Storage humidity: Relative humidity ≤ 90%

Storage period: 12 months

Storage site: Indoors with no corrosive gas and air circulation

### Waste disposal

The equipment is manufactured with materials, which do not contain any toxic or poisonous materials dangerous to the operator.

When the equipment is scrapped, it should be dismantled separating components according to the type of materials.

Do not dispose of the equipment with normal waste. The European Directive 2002/96/EC on Waste Electrical and Electronic Equipment states the electrical equipment that has reached its end of life must be collected separately and returned to an environmentally compatible recycling facility.

In order to comply with WEEE regulations in your country you should contact your supplier.

### RoHS Compliance Declaration

We herewith confirm, that the above mentioned product does not contain any of the restricted substances as listed in EU Directive 2011/65/EC in concentrations above the limits as specified therein. Disclaimer: Please note that this confirmation is given to the best of our present knowledge and belief. Nothing herein represents and/or may be interpreted as warranty within the meaning of the applicable warranty law.



## STATEMENT OF WARRANTY

All new JASIC EVO20 welding, plasma cutters and multi-process machines are sold through our partner Wilkinson Star Limited within the United Kingdom and Ireland shall be warranted to the original owner, non transferable, against failure due to defective materials or production.

The warranty period is 5 years following the date of purchase and we recommend you register your product online within 28 days of purchase.

The original invoice is documentation for the standard warranty period. The warranty period is based on a single shift pattern.

Defective units shall be repaired or replaced by the company at our workshop. The company may opt to refund the purchase price (less any costs and depreciation due to use and wear).

The company reserves the right to alter the warranty conditions at any time with effect for the future.

A prerequisite for the full warranty is that products are operated in accordance with the operating instructions supplied, observing the relevant installation and any legal requirements recommendations and guidelines and carrying out the maintenance instructions shown in the operator manual. This should be carried out by a suitably qualified competent person.

Warranty claims will only be accepted from authorised Jasic distributors and in the unlikely event of a problem this should be reported to the technical support team to review the claim.

The customer has no claim to loan or replacement products whilst repairs are being performed.

The following falls outside the scope of the warranty:

- Defects due to natural wear and tear
- Failure to observe the operating and maintenance instructions
- Connection to an incorrect or faulty mains supply
- Overloading during use
- Any modifications that are made to the product without the prior written consent
- Software errors due incorrect operation
- Any repairs that are carried out using non-approved spare parts
- Any transport or storage damage
- Direct or indirect damage as well as any loss of earnings are not covered under the warranty
- External damage such as fire or damage due to natural causes e.g. flooding
- Warranty repairs carried out by non-authorised Jasic distributors.

### NOTE:

**Under the terms of the warranty, welding torches, their consumable parts, wire feed unit drive rolls and guide tubes, work return cables and clamps, electrode holders, connection and extension cables, mains and control leads, plugs, wheels, coolant and accessories are covered with a 3 month warranty.**

Jasic shall in no event be responsible for any third party expenses or expenses/costs or any indirect or consequential expenses/costs.

Jasic will submit an invoice for any repair work performed outside the scope of the warranty. A quotation for any non warranty will be raised prior to any repairs being carried out.

The decision about repair or replacement of the defective part(s) is made by Jasic. The replaced part(s) remain(s) Jasic property.

Warranty extends only to the machine, its accessories and parts contained inside. No other warranty is expressed or implied. No warranty is expressed or implied in regards to the fitness of the product for any particular application or use.

If in our judgment you fail, or we suspect that you have failed, to comply with any term or provision of the product warranty terms, we reserve the right to deny you access to our services (or any part thereof).

For further information on Jasic product warranty terms and product warranty registration please visit:

**[www.jasic.co.uk/warranty-information](http://www.jasic.co.uk/warranty-information)**

**[www.jasic.co.uk/warranty-registration](http://www.jasic.co.uk/warranty-registration)**







**Wilkinson Star Limited**

Shield Drive  
Wardley Industrial Estate  
Worsley  
Manchester  
UK  
M28 2WD

**+44(0)161 793 8127**



[Jasic.co.uk](http://Jasic.co.uk)

 **JASIC®** | Passionate About Your Welding

[www.jasic.co.uk](http://www.jasic.co.uk)

January 2024 Issue 4